

ebm-papst Mulfingen GmbH & Co. KG
 Bachmühle 2
 D-74673 Mulfingen
 Phone +49 (0) 7938 81-0
 Fax +49 (0) 7938 81-110
 info1@de.ebmpapst.com
 www.ebmpapst.com

CONTENTS

1. SAFETY REGULATIONS AND INFORMATION	1
1.1 Hazard levels for warnings	1
1.2 Staff qualifications	1
1.3 Basic safety rules	1
1.4 Voltage	1
1.5 Safety and protective features	2
1.6 Electromagnetic radiation	2
1.7 Mechanical movement	2
1.8 Deflagration	2
1.9 Emissions	2
1.10 Hot surface	3
1.11 Transport	3
1.12 Storage	3
2. INTENDED USE	3
3. TECHNICAL DATA	4
3.1 Product drawing	4
3.2 Nominal data	5
3.3 Technical description	5
3.4 Mounting data	5
3.5 Transport and storage conditions	5
3.6 Electromagnetic compatibility	5
4. CONNECTION AND STARTUP	6
4.1 Mechanical connection	6
4.2 Electrical connection	6
4.3 Plug connection	7
4.4 Connection diagram	8
4.5 Checking connections	9
4.6 Switching on the device	9
4.7 Switching off the device	9
5. INTEGRATED PROTECTIVE FEATURES	9
6. MAINTENANCE, MALFUNCTIONS, POSSIBLE CAUSES AND REMEDIES	9
6.1 Cleaning	10
6.2 Safety inspection	10
6.3 Disposal	10

1. SAFETY REGULATIONS AND INFORMATION

Read these operating instructions carefully before starting work on the device. Observe the following warnings to prevent malfunctions or danger to persons.

These operating instructions are to be regarded as part of the device. The device is only to be sold or passed on together with the operating instructions.

These operating instructions may be duplicated and distributed to inform about potential dangers and their prevention.

1.1 Hazard levels for warnings

These operating instructions use the following hazard levels to indicate potentially hazardous situations and important safety regulations:



DANGER

Indicates an imminently hazardous situation which will result in death or serious injury if the specified actions are not taken. Compliance with the instructions is imperative.

WARNING

Indicates a potentially hazardous situation which can result in death or serious injury if the specified actions are not taken. Exercise extreme caution while working.

CAUTION

Indicates a potentially hazardous situation which can result in minor or moderate injury or damage to property if the specified actions are not taken.

NOTE

A potentially harmful situation can occur and, if not avoided, can lead to property damage.

1.2 Staff qualifications

The device may only be transported, unpacked, installed, operated, maintained and otherwise used by suitably qualified, trained and authorized technical staff.

Only authorized specialists are permitted to install the device, to carry out a test run and to perform work on the electrical installation.

1.3 Basic safety rules

The safety hazards associated with the device must be assessed again following installation in the final product.

The locally applicable industrial safety regulations are always to be observed when working on the device.

Keep the workplace clean and tidy. Untidiness in the work area increases the risk of accidents.

Note the following when working on the device:

- ⇒ Do not perform any modifications, additions or conversions on the device without the approval of ebm-papst.

1.4 Voltage

- ⇒ Check the device's electrical equipment at regular intervals; see Chapter 6.2 Safety inspection.

- ⇒ Replace loose connections and defective cables immediately.



DANGER

Electrically charged device

Risk of electric shock

- When working on an electrically charged device, stand on a rubber mat.

WARNING**Live terminals and connections even with device switched off**

Electric shock

- Wait five minutes after disconnecting the voltage at all poles before opening the device.

CAUTION**In the event of a fault, the rotor and the impeller will be energized**

The rotor and the impeller have basic insulation.

- Do not touch the rotor and impeller once installed.

CAUTION**If control voltage or a stored speed set value is applied, the motor will restart automatically, e.g. after a power failure.**

Risk of injury

- Keep out of the device's danger zone. # When working on the device, switch off the line voltage and ensure that it cannot be switched back on.
- Wait until the device comes to a stop.
- After working on the device, remove any tools or other objects from the device.

1.5 Safety and protective features**DANGER****Protective device missing and protective device not functioning**

Without a protective device there is a risk of serious injury, for instance when reaching into the device during operation.

- Operate the device only with a fixed protective device and guard grille.
- The fixed protective device must be able to withstand the kinetic energy of a fan blade that becomes detached at maximum speed. There must not be any gaps which it is possible to reach into with the fingers, for example.
- The device is a built-in component. As the operator, you are responsible for ensuring that the device is secured adequately.
- Stop the device immediately if you notice a missing or ineffective protective device.

1.6 Electromagnetic radiation

Interference from electromagnetic radiation is possible, e.g. in conjunction with open- and closed-loop control devices.

If impermissible radiation levels occur following installation, appropriate shielding measures have to be taken by the user.

NOTE**Electrical or electromagnetic interference after installing the device in customer equipment.**

- Verify that the entire setup is EMC-compliant.

1.7 Mechanical movement**DANGER****Danger of injury from open blower**

Escaping gas. When the blower is open, you come into contact with rotating and electrically live parts. Escaping gas can also cause explosions.

- Never open the blower.

WARNING**Rotating device**

Long hair and dangling items of clothing, jewelry and the like can become entangled and be pulled into the device. Injuries can result.

- Do not wear any loose-fitting or dangling clothing or jewelry while working on rotating parts.
- Protect long hair with a cap.

WARNING**Ejected parts**

Missing protective devices may allow fan blades to be ejected and cause injuries.

- Take appropriate safety measures.
The protective devices must prevent contact with rotating parts and the circuit board.

1.8 Deflagration**DANGER****Gas escaping through leaky housing after deflagration**

Risk of injury

- After a deflagration, verify that the gas blower's housing is sealed.
- Replace any gas blower that has a leaky housing.

**DANGER****Fire and deflagration hazard**

The gas blower is not approved according to the explosion protection directives. Rotating parts can scrape against stationary parts. This can lead to sparking and chipping. The surface temperature can rise, resulting in a fire.

- Check which hazards arise from installing, operating, servicing or disposing of the gas blower in conjunction with your device.
Avoid any such hazards.
Carry out all necessary measures.

1.9 Emissions**WARNING****Depending on the installation and operating conditions, the sound pressure level may exceed 70 dB(A).**

Risk of noise-induced hearing loss

- Take appropriate technical safety measures.
- Protect operating personnel with appropriate safety equipment such as hearing protection.
- Also observe the requirements of local agencies.

1.10 Hot surface



CAUTION

High temperature on electronics housing

Risk of burns

→ Ensure sufficient protection against accidental contact.

1.11 Transport

NOTE

Transporting the blower

- Transport the blower in its original packaging only.
- Secure the blower so it cannot slip, e.g. by using a lashing strip.



NOTE

Transporting the device

→ Transport the device in its original packaging only.

1.12 Storage

- ⇒ Store the device, partially or fully assembled, in a dry place, protected against the weather and free from vibration, in the original packaging in a clean environment.
- ⇒ Protect the device against environmental effects and dirt until final installation.
- ⇒ We recommend storing the device for no longer than one year in order to guarantee trouble-free operation and the longest possible service life.
- ⇒ Even devices explicitly intended for outdoor use are to be stored as described prior to commissioning.
- ⇒ Maintain the storage temperature, see Chapter 3.5 Transport and storage conditions.

2. INTENDED USE

The device is exclusively designed as a built-in device for conveying air and gases according to its technical data.

Any other usage above and beyond this does not conform with the intended purpose and constitutes misuse of the device.

Customer equipment must be capable of withstanding the mechanical and thermal stresses that can arise from this product. This applies for the entire service life of the equipment in which this product is installed.

Intended use also includes

- Conveying air in gas burners.
- conveying air at an ambient air pressure between 750 mbar and 1050 mbar.
- Following the operating instructions.
- Using the device within the permitted ambient temperature range; see Chapter 3.5 Transport and storage conditions and Chapter 3.2 Nominal data.
- Using the device only in stationary systems.
- Installing the device in an integrated system for conveying air.
- Commissioning the built-in component only after installation in the customer equipment.
- Operating the device with all protective devices.
- Use of the device in stationary systems only.

Improper use

In particular, operating the device in the following ways is prohibited and could be hazardous:

- Operating the device in an unbalanced state, e.g. due to dirt deposits or ice formation.
- Resonant operation, operation with severe vibration. This also includes vibration transmitted to the fan from the customer installation.
- Conveying a medium that contains abrasive particles.
- Conveying a highly corrosive medium.
- Conveying a medium with high dust content, e.g. suctioning off sawdust.
- Operating the gas blower in an environment that contains flammable gases or dust or combustible solids or fluids.
- Conveying air/gas mixtures outside of an integrated system satisfying the requirements described above.
- Using the blower as a safety component or to perform safety-related functions.
- Operation in medical equipment with a life-sustaining or life-support function.
- Contact with materials that could damage blower parts, e.g. liquids during cleaning.
- Operation with completely or partially disassembled or manipulated protective devices.
- Exposure to radiation which could damage blower parts, e.g. strong UV radiation.
- Operation with external vibrations.
- Operating the device in an explosive atmosphere.
- Operation with completely or partially disassembled or manipulated protective devices.
- In addition, all applications not listed among the intended uses.



3. TECHNICAL DATA

3.1 Product drawing

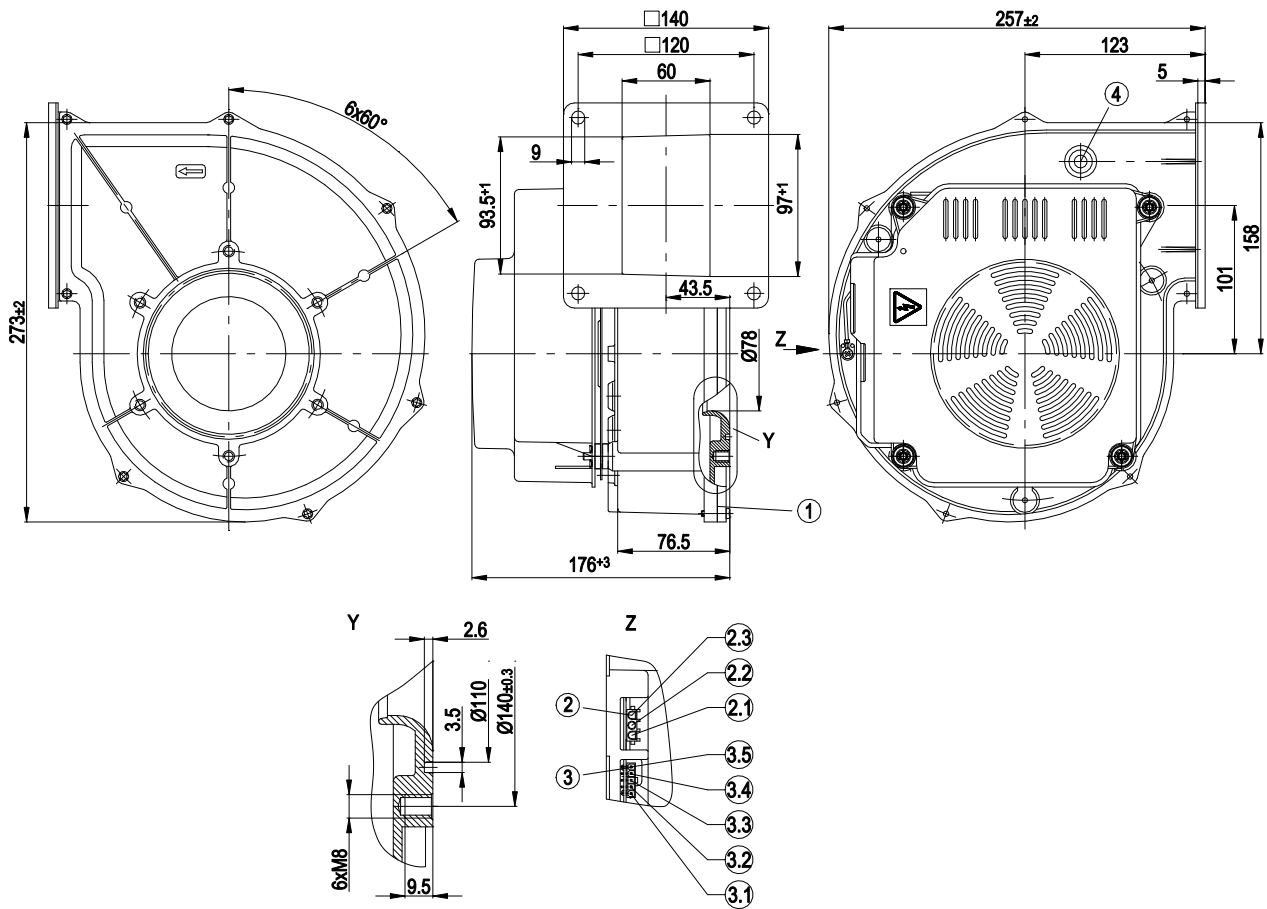

All dimensions in mm.

1	Housing side parts sealed with NBR round cord (pentane-resistant)
Z	View Z
2	3-pole header, mating connector (not included in scope of delivery): tyco no. 350 766-1, socket: tyco no. 926 884-1
2.1	L
2.2	N
2.3	PE
3	5-pole header; mating connector (not included in scope of delivery): Molex no. 39-01-4050; socket: Molex no. 39-00-0059
3.1	(+)
3.2	Speed monitoring
3.3	not used
3.4	PWM input
3.5	(-)
4	Pressure tap possible



You can control the blower either via the 0-10 VDC input or the PWM input. Attention: The inputs cannot be used simultaneously.

3.2 Nominal data

Motor	M1G074-CF
Phase	1~
Nominal voltage / VAC	115
Frequency / Hz	50/60
Method of obtaining data	fa
Speed (rpm) / min ⁻¹	5730
Power consumption / W	345
Current draw / A	4.0
Min. ambient temperature / °C	-25
Max. ambient temperature / °C	55
Min. temp. of flow medium / °C	-25
Max. temp. of flow medium / °C	+80

ml = Max. load · me = Max. efficiency · fa = Free air
cs = Customer specification · ce = Customer equipment

Subject to change

3.3 Technical description

Weight	4.35 kg
Fan size	170 mm
Rotor surface	Painted black
Cover material	Polyflam RPP 374-ND CS1 (UL 97-V0)
Impeller material	Sheet aluminum
Housing material	Die-cast aluminum
Direction of rotation	Clockwise, viewed toward rotor
Degree of protection	IP20
Insulation class	"B"
Moisture (F) / Environmental (H) protection class	H0 - dry environment
Installation position	Any
Cooling hole/opening	On rotor side
Premixing	If gas is premixed in the blower, then a special blower must be used.
Motor bearing	Ball bearing
Technical features	- PWM control input - Motor current limitation - Tach output - Thermal overload protection for motor
Touch current according to IEC 60990 (measuring circuit Fig. 4, TN system)	≤ 3.5 mA
Electrical hookup	With plug
Motor protection	Thermal overload protector (TOP) internally connected
Approval	UL 507; CSA C22.2 No. 113



With regard to cyclic speed loads, note that the rotating parts of the device are designed for a maximum of one million load cycles. If you have special questions, consult ebm-papst for support.

⇒ Use the device in accordance with its degree of protection.

Information on surface quality

The surfaces of the products conform to the generally applicable industrial standard. The surface quality may change during the production period. This has no effect on strength, dimensional stability and dimensional accuracy.

The color pigments in the paints used perceptibly react to UV light over the course of time. This does not however in any way affect the technical properties of the products. The product is to be protected against UV radiation to prevent the formation of patches and fading. Changes in color are not a reason for complaint and are not covered by the warranty.

3.4 Mounting data

For screw clearance, see Chapter 3.1 Product drawing

Strength class of screws	8.8
--------------------------	-----

⇒ Secure the screws against unintentional loosening (e.g. use self-locking screws).

Any further mounting data required can be taken from the product drawing or Section Chapter 4.1 Mechanical connection.

3.5 Transport and storage conditions

Max. permitted ambient temp. for motor (transport/storage)	+80 °C
Min. permitted ambient temp. for motor (transport/storage)	-40 °C

3.6 Electromagnetic compatibility

EMC immunity to interference	According to EN 61000-6-2
EMC interference emission	According to EN 61000-6-3 (household environment)

4. CONNECTION AND STARTUP

4.1 Mechanical connection



DANGER

Gas leaking from poorly sealed housing

Risk of fatal injury

- Prior to startup, verify whether the gas blower's housing is pressure-tight.
When doing so, seal off the intake and outlet openings as well as the shaft opening.
- In addition, verify that no rotating parts scrape against stationary parts.



DANGER

Leaks may occur.

Due to its design, the gas blower is not tightly sealed, e.g. at the shaft opening. This may result in leaks during operation. Deflagrations may also cause long-term damage or deformation of the housing, which can result in leaks. An air/gas mixture may accumulate outside of the gas blower. The blower can explode. Severe injuries can result.

- Check which hazards arise from installing, operating, servicing or disposing of the gas blower in conjunction with your device.
Avoid any such hazards.
Carry out all necessary measures.



CAUTION

Cutting and crushing hazard when removing blower from packaging



- Carefully remove the blower from its packaging, touching only the housing. Strictly avoid shocks.
- Wear safety shoes and cut-resistant safety gloves.

NOTE

Damage to the device from vibration

Bearing damage, shorter service life

- The fan must not be subjected to force or excessive vibration from sections of the installation. #If the fan is connected to air ducts, the connection should be isolated from vibration, e.g. using compensators or similar elements. #Ensure stress-free attachment of the fan to the substructure.

- ⇒ Check the device for transport damage. Damaged devices are not to be installed.
- ⇒ Install the undamaged device in accordance with your application.



CAUTION

Possible damage to the device

If the device slips during installation, serious damage can result.

- Ensure that the device is securely positioned at its place of installation until all fastening screws have been tightened.
- The fan must not be strained on fastening.

4.2 Electrical connection



DANGER

Voltage on the device

Electric shock

- Always connect a protective earth first.
- Check the protective earth.



DANGER

Faulty insulation

Risk of fatal injury from electric shock

- Use only cables that meet the specified installation regulations for voltage, current, insulation material, capacity, etc.
- Route cables so that they cannot be touched by any rotating parts.



DANGER

Electrical charge (>50 µC) between phase conductor and protective earth connection after switching off supply with multiple devices connected in parallel.

Electric shock, risk of injury

- Ensure sufficient protection against accidental contact.
Before working on the electrical hookup, short the supply and PE connections.

CAUTION

Voltage

The device is a built-in component and has no disconnecting switch.

- Only connect the device to circuits that can be switched off with an all-pole disconnection switch.
- When working on the device, secure the system/machine in which the device is installed so as to prevent it from being switched back on.

NOTE

Water ingress into wires or cables

Water ingress at the customer end of the cable can damage the device.

- Make sure the end of the cable is connected in a dry environment.



The control voltage circuit is not electrically isolated. Only connect the device to circuits that can be switched off with an all-pole disconnection switch.

4.2.1 Requirements

- ⇒ Check whether the information on the nameplate matches the connection data.
- ⇒ Before connecting the device, make sure the power supply matches the device voltage.
- ⇒ Only use cables designed for the current level indicated on the nameplate.
For determining the cross-section, note the sizing criteria according to EN 61800-5-1. The protective earth must have a cross-section equal to or greater than that of the phase conductor.
We recommend the use of 105 °C cables. Ensure that the minimum cable cross-section is at least AWG 26 / 0.13 mm².

4.2.2 Reactive currents



Because of the EMC filter integrated for compliance with EMC limits (interference emission and immunity to interference), reactive currents can be measured in the supply line even when the motor is at a standstill and the line voltage is switched on.

- The values are typically in the range < 250 mA
- At the same time, the effective power in this operating state (operational readiness) is typically < 4 W.

4.2.3 Locked-rotor protection



Due to the locked-rotor protection, the starting current (LRA) is equal to or less than the nominal current (FLA).

4.3 Plug connection

4.3.1 Making supply connections

CAUTION

Voltage

The device is a built-in component and has no disconnecting switch.

- Connect the device to a suitable tripping unit.
 - Only connect the device to circuits that can be switched off with an all-pole disconnection switch.
 - When working on the device, secure the system/machine in which the device is installed so as to prevent it from being switched back on.
- ⇒ Check your connector's pin assignment.
- ⇒ Connect the built-in connector with the mating connector.
- ⇒ Ensure that the connector is properly engaged.

4.4 Connection diagram

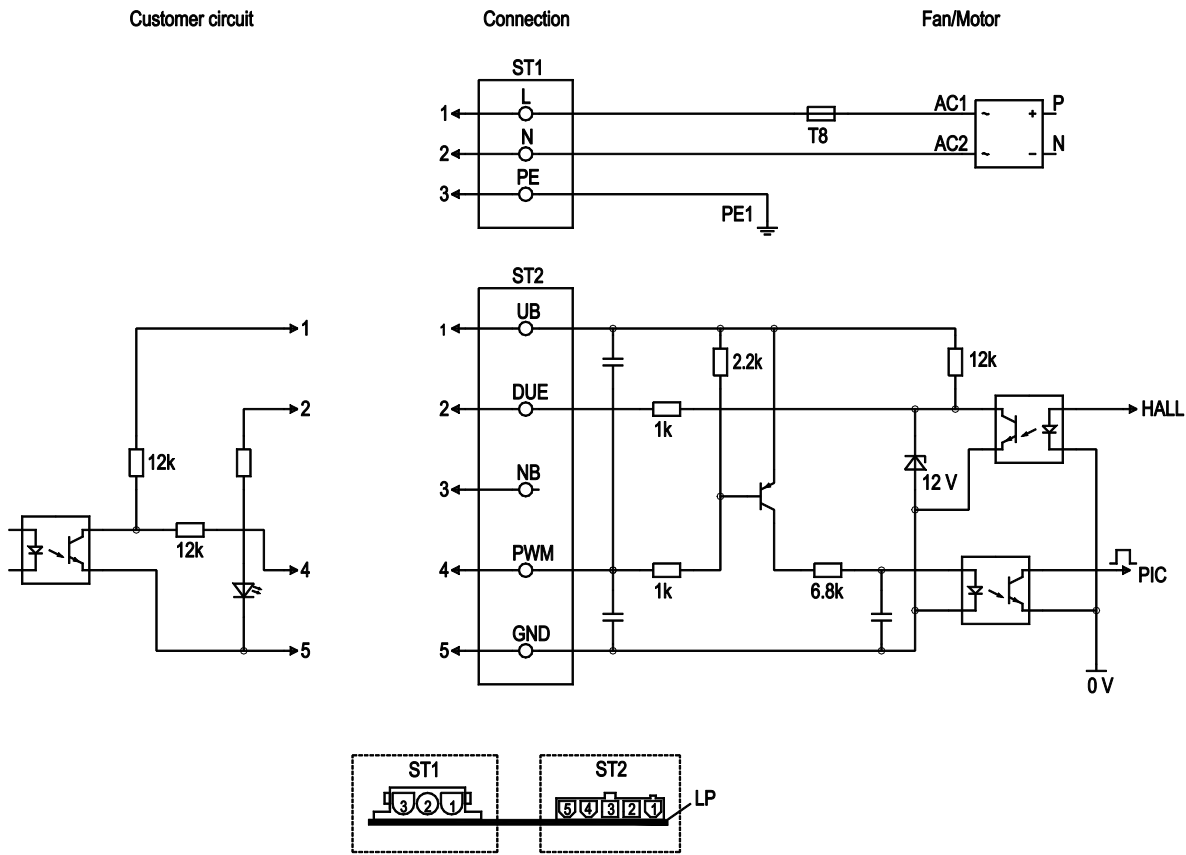

Drawing preliminary!

No.	Conn.	Designation	Function/assignment
ST1	1, 2, 3	L, N, PE	Power supply 115 VAC, 50-60 Hz, neutral conductor, protective earth
ST2	1	UB	external voltage 24-45 VDC
ST2	2	Tach	DUE connection, monitoring output, 3 pulses per revolution, Isource 1mA
ST2	3	N.C.	not used
ST2	4	PWM	PWM - 2-6 kHz control input, PWM on n = 100%, PWM low n = 0%
ST2	5	GND	GND - Connection for control interface

4.5 Checking connections

- ⇒ Ensure isolation from supply (all phases).
- ⇒ Make sure a restart is impossible
- ⇒ Check whether the mating connector is properly engaged with the built-in connector.
- ⇒ Check that the mating connector is correctly attached to the cable.

4.6 Switching on the device

The device may only be switched on if it has been installed properly and in accordance with its intended use, including the required safety mechanisms and professional electrical hookup. This also applies for devices which have already been equipped with plugs and terminals or similar connectors by the customer.



WARNING

Hot motor housing

Risk of fire

- Ensure that no combustible or flammable materials are located close to the blower.
- ⇒ Before switching on, check the device for visible external damage and make sure the protective devices are functional.
- ⇒ Check the fan's air flow paths for foreign matter and remove any foreign matter found.
- ⇒ Apply 0 VDC to the 0-10 V control input, if you are using it
- ⇒ Apply 0% PWM to the PWM control input, if you are using it
- ⇒ Apply the nominal supply voltage.
- ⇒ Start the device by changing the input signal.



NOTE

Damage to the device from vibration

Bearing damage, shorter service life

- Low-vibration operation of the fan must be ensured over the entire speed control range. #Severe vibration can arise for instance from inexpert handling, transportation damage and resultant imbalance or be caused by component or structural resonance. #Speed ranges with excessively high vibration levels and possibly resonant frequencies must be determined in the course of fan commissioning. #Either run through the resonant range as quickly as possible with speed control or find another remedy. # Operation with excessively high vibration levels can lead to premature failure.

4.7 Switching off the device

Switching off the device during operation:

- ⇒ Switch off the device via the control input.
- ⇒ Do not switch the motor (e.g. in cyclic operation) on and off via power supply.

Switching off the device for maintenance:

- ⇒ Switch off the device via the control input.
- ⇒ Do not switch the motor (e.g. in cyclic operation) on and off via power supply.
- ⇒ Disconnect the device from the power supply.
- ⇒ When disconnecting, be sure to disconnect the ground connection last.

5. INTEGRATED PROTECTIVE FEATURES

The integrated protective functions cause the motor to switch off automatically in the event of the faults described in the table.

Fault	Safety feature description/function
Rotor position detection error	An automatic restart follows.
Blocked rotor	⇒ After the blockage is removed, the motor restarts automatically.

6. MAINTENANCE, MALFUNCTIONS, POSSIBLE CAUSES AND REMEDIES

Do not perform any repairs on your device. Send the device to ebmpapst for repair or replacement.

WARNING

Live terminals and connections even with device switched off

Electric shock

- Wait five minutes after disconnecting the voltage at all poles before opening the device.

CAUTION

If the control signal of a blower that is connected to the supply network is removed, the motor can restart automatically.

Risk of injury

- When working on the blower, switch off the line voltage and ensure that it cannot be switched back on.

- Wait until the device comes to a stop.

CAUTION

Device still electrically charged after being switched off

Electric shock if touched

- Wait 5 minutes after disconnecting the voltage at all poles before touching the device.

CAUTION

If control voltage or a stored speed set value is applied, the motor will restart automatically, e.g. after a power failure.

Risk of injury

- Keep out of the device's danger zone. # When working on the device, switch off the line voltage and ensure that it cannot be switched back on.

- Wait until the device comes to a stop.

- After working on the device, remove any tools or other objects from the device.



If the blower is out of use for some time, e.g. when in storage, we recommend switching the blower on for at least 2 hours to allow any condensation to evaporate and to move the bearings.

Malfunction/fault	Possible cause	Possible remedy
Impeller not running smoothly	Imbalance in rotating parts	Clean the device; replace it if imbalance persists after cleaning. Make sure no weight clips are removed during cleaning.



Motor not turning	Mechanical blockage	Switch off, isolate from supply and remove mechanical blockage.
	Line voltage faulty	Check line voltage, restore power supply, apply control signal.
	Faulty connection	Isolate from supply, correct connection; see connection diagram.
	Thermal overload protector activated	Allow motor to cool off, locate and rectify cause of error, release restart lockout if necessary
Motor/electronics overtemperature	Deficient cooling	Improve cooling. Let the device cool down. To reset the error message, switch off the line voltage for at least 25 s and then switch it on again.
	Ambient temperature too high	Reduce the ambient temperature. Reset by reducing control input to 0.
	Impermissible point of operation	Correct the operating point. Let the device cool down.
Deflagration	Leakage of the air/gas mixture being conveyed	Check for leaks; replace blower if not properly sealed



In the event of further malfunctions, contact ebm-papst.

6.1 Cleaning

NOTE

The device does not need to be cleaned.

6.2 Safety inspection

NOTE

High-voltage test

The integrated EMC filter has Y capacitors. The tripping current is exceeded when AC testing voltage is applied.

→ Test the device with DC voltage when you perform the legally required high-voltage test. The voltage to be used corresponds to the peak value of the AC voltage required by the standard.

What to check	How to check	How often	What action?
Contact protection cover for intactness or damage	Visual inspection	At least every 6 months	Repair or replacement of device

Device for damage to blades and housing	Visual inspection	At least every 6 months	Replacement of device
Fastening the cables	Visual inspection	At least every 6 months	Fasten
Fastening the protective earth terminal	Visual inspection	At least every 6 months	Fasten
Insulation of cables for damage	Visual inspection	At least every 6 months	Replace cables
Condensation drainage holes for clogging, where necessary	Visual inspection	At least every 6 months	Open holes
Abnormal bearing noise	acoustic	At least every 6 months	Replace device

6.3 Disposal

For ebm-papst, environmental protection and resource preservation are top priority corporate goals.

ebm-papst operates an environmental management system which is certified in accordance with ISO 14001 and rigorously implemented around the world on the basis of German standards.

Right from the development stage, ecological design, technical safety and health protection are fixed criteria.

The following section contains recommendations for ecological disposal of the product and its components.

6.3.1 Country-specific legal requirements



NOTE

Country-specific legal requirements

Always observe the applicable country-specific legal regulations with regard to the disposal of products or waste occurring in the various phases of the life cycle. The corresponding disposal standards are also to be heeded.

6.3.2 Disassembly

Disassembly of the product must be performed or supervised by qualified personnel with the appropriate technical knowledge.

The product is to be disassembled into suitable components for disposal employing standard procedures for motors.



WARNING

Heavy parts of the product may drop off. Some of the product components are heavy. These components could drop off during disassembly.

This can result in fatal or serious injury and material damage.

→ Secure components before unfastening to stop them falling.

6.3.3 Component disposal

The products are mostly made of steel, copper, aluminum and plastic. Metallic materials are generally considered to be fully recyclable. Separate the components for recycling into the following categories:

- Steel and iron
- Aluminum
- Non-ferrous metal, e.g. motor windings
- Plastics, particularly with brominated flame retardants, in accordance with marking
- Insulating materials

- Cables and wires
- Electronic scrap, e.g. circuit boards

Only ferrite magnets and not rare earth magnets are used in external rotor motors from ebm-papst Mulfingen GmbH & Co. KG.

⇒ Ferrite magnets can be disposed of in the same way as normal iron and steel.

Electrical insulating materials on the product, in cables and wires are made of similar materials and are therefore to be treated in the same manner.

The materials concerned are as follows:

- Miscellaneous insulators used in the terminal box
- Power cables
- Cables for internal wiring
- Electrolytic capacitors

Dispose of electronic components employing the proper procedures for electronic scrap.



→ Please contact ebm-papst for any other questions on disposal.