

G3G250-GN17-01

## EC centrifugal fan

backward curved, single inlet

with housing (flange), Gas blower for gas-condensing heating



### ebm-papst Landshut GmbH

Hofmark-Aich-Str. 25 · D-84030 Landshut

Phone +49 871 707-0

Fax +49 871 707-465

info3@de.ebmpapst.com

www.ebmpapst.com

### Nominal data

Type	G3G250-GN17-01	
Motor	M3G084-FA	
Phase		1~
Nominal voltage	VAC	230
Nominal voltage range	VAC	208 .. 240
Frequency	Hz	50/60
Type of data definition		ml
Speed	min <sup>-1</sup>	4800
Power input	W	1150
Current draw	A	5.7 @ 208 V
Min. ambient temperature	°C	-20
Max. ambient temperature	°C	60
Min. temp. of flow medium	°C	0
Max. temp. of flow medium	°C	60

ml = max. load · me = max. efficiency · rfa = running at free air · cs = customer specs · cu = customer unit  
Subject to alterations



# EC centrifugal fan

backward curved, single inlet

with housing (flange), Gas blower for gas-condensing heating

## Technical features

<b>Mass</b>	13.2 kg
<b>Size</b>	250 mm
<b>Surface of rotor</b>	Coated in black
<b>Material of protective cover</b>	Polyflam RPP 374-ND CS1 (UL 97-V0)
<b>Material of impeller</b>	Aluminum sheet
<b>Housing material</b>	Die-cast aluminum
<b>Number of blades</b>	7
<b>Direction of rotation</b>	Clockwise, seen on rotor
<b>Type of protection</b>	IP 20
<b>Insulation class</b>	"B"
<b>Max. permissible ambient motor temp. (transp./ storage)</b>	+80 °C
<b>Min. permissible ambient motor temp. (transp./storage)</b>	-40 °C
<b>Mounting position</b>	Any
<b>Condensate discharge holes</b>	Rotor-side
<b>Operation mode</b>	S1
<b>Motor bearing</b>	Ball bearing
<b>Technical features</b>	<ul style="list-style-type: none"> <li>- Tach output</li> <li>- Over-temperature protected electronics / motor</li> <li>- PFC, active</li> <li>- Motor current limit</li> <li>- Line undervoltage / phase failure detection</li> <li>- PWM control input</li> <li>- Control input 0-10 V</li> </ul>
<b>EMC interference immunity</b>	Acc. to EN 61000-6-2 (industrial environment)
<b>EMC interference emission</b>	Acc. to EN 61000-6-4 (industrial environment)
<b>EMC harmonics</b>	Acc. to EN 61000-3-2/3
<b>Leakage current</b>	<= 3.5 mA
<b>Electrical leads</b>	With plug
<b>Motor protection</b>	Locked-rotor protection
<b>Protection class</b>	I
<b>Approval</b>	CCC; CSA C22.2 Nr.113; UL 507



# EC centrifugal fan

backward curved, single inlet

with housing (flange), Gas blower for gas-condensing heating

## Product drawing

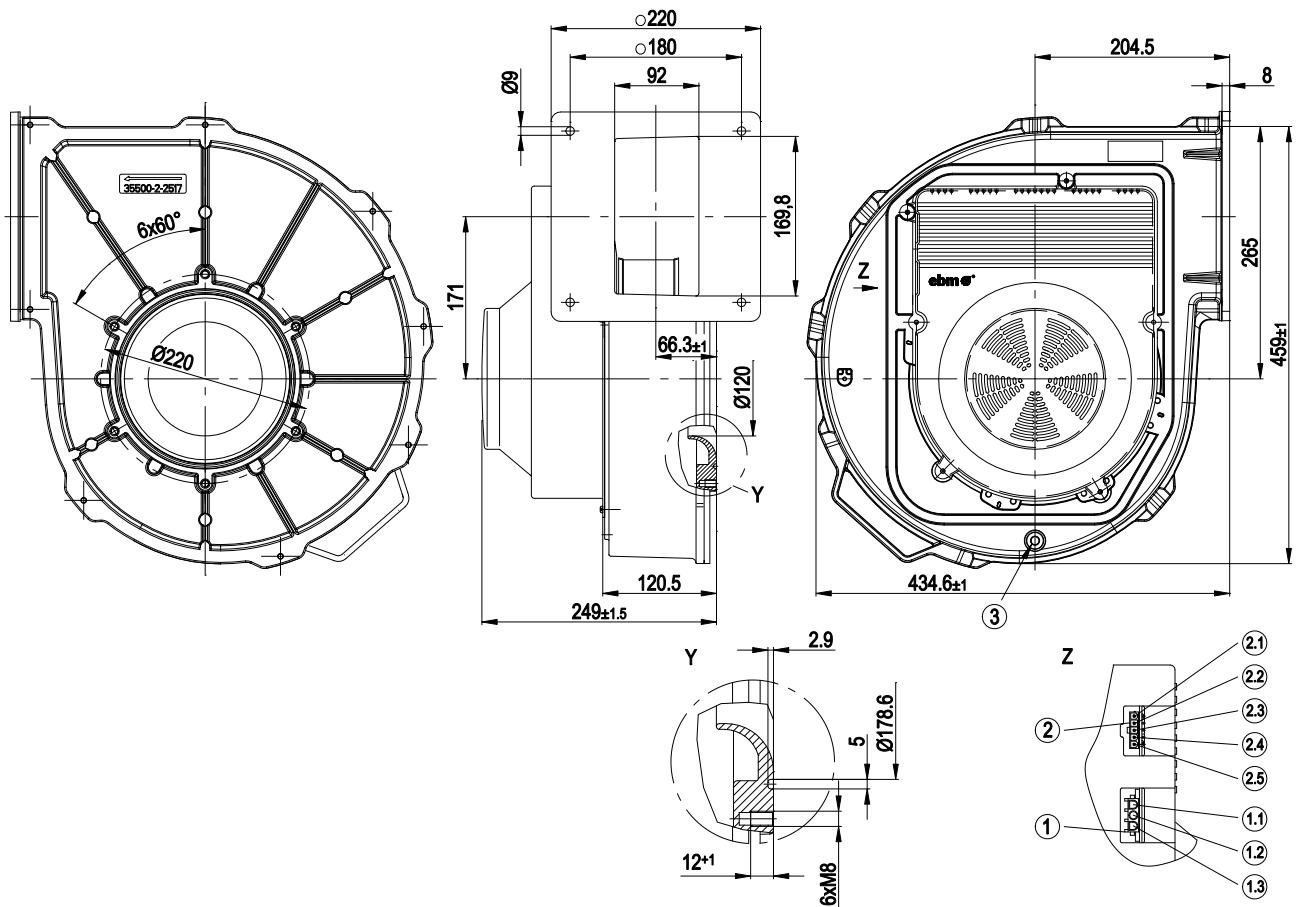

1	3-pole strip to fit mating connector (not included in standard scope of delivery) tyco No. 350766-1, female connector tyco No. 926884-1
1.1	L
1.2	N
1.3	PE
2	5-pole strip to fit mating connector (not included in standard scope of delivery) Molex No. 39-01-4050, female connector Molex No. 39-00-0059
2.1	+
2.2	Speed monitoring
2.3	0-10 VDC control input
2.4	PWM input
2.5	-
3	Pressure tap optionally available
Y	Detail Y
Z	View Z / plug assignment

# EC centrifugal fan

backward curved, single inlet

with housing (flange), Gas blower for gas-condensing heating

## Connection screen

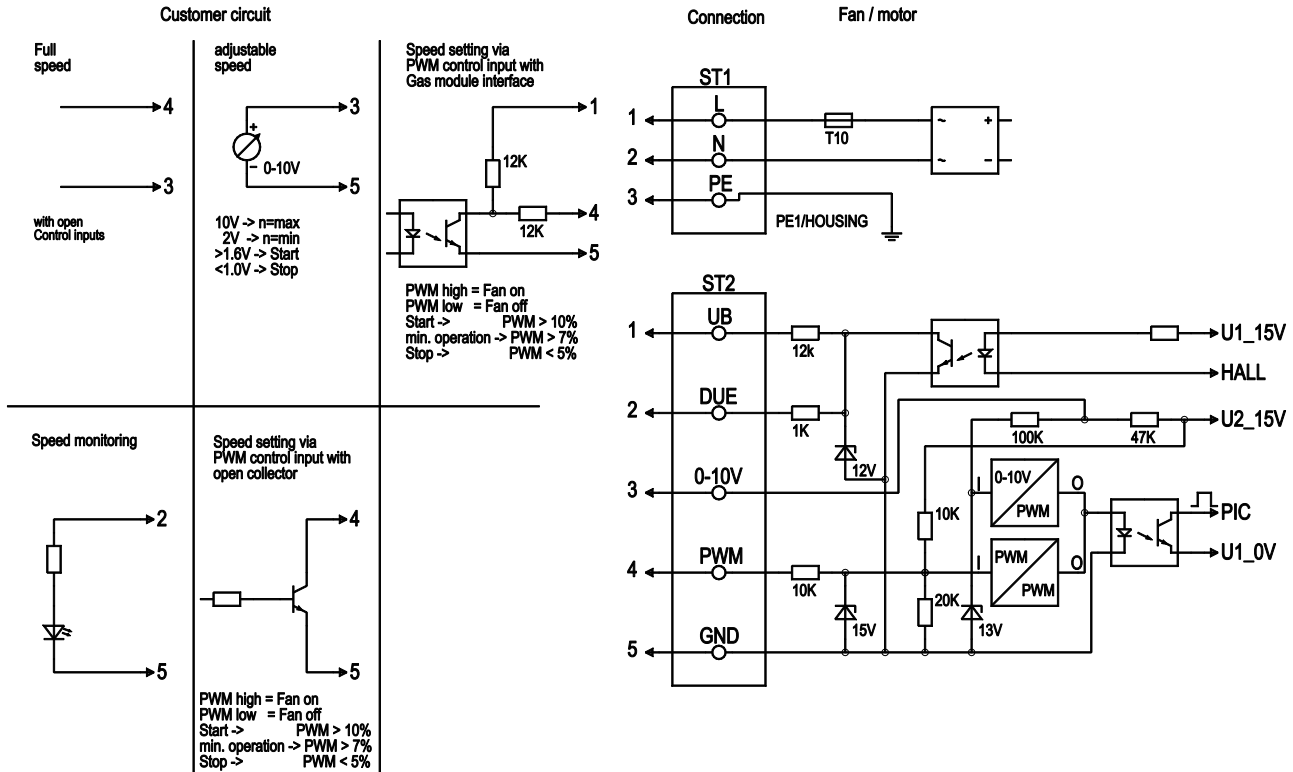

No.	Pin	Signal	Function / assignment
ST1	1; 2; 3	L; N; PE	Power supply 230 VAC, 50 - 60 Hz, phase, neutral, protective earth
St2	1	UB	External voltage 16 - 45 VDC, residual ripple +/- 3.5%, SELV
ST2	2	DUE	Speed monitoring, 3 pulses per revolution, SELV
ST2	3	0 - 10 V	Control input 0 - 10 V, impedance 100k, SELV
ST2	4	PWM	Control input PWM, 1 - 6 kHz, SELV
ST2	5	GND	GND - Connection for control interface, SELV



# EC centrifugal fan

backward curved, single inlet

with housing (flange), Gas blower for gas-condensing heating

## Charts: Air flow 50 Hz

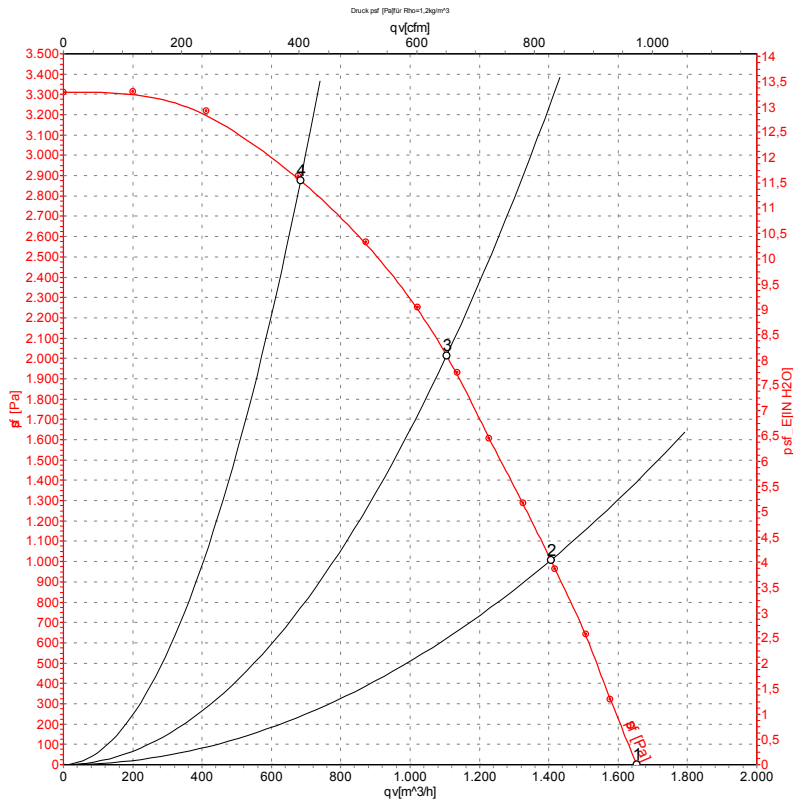

Measurement: LU-76445

Air performance measured as per ISO 5801 Installation category A. For detailed information on the measuring set-up, please contact ebm-papst. Suction-side noise levels: LwA measured as per ISO 13347 / LpA measured with 1m distance to fan axis. The values given are valid under the measuring conditions mentioned above and may vary according to the actual installation situation. With any deviation from the standard set-up, the specific values have to be checked and reviewed with the unit installed.

## Measured values

	U	f	n	P <sub>e</sub>	I	LpA <sub>in</sub>	qv	p <sub>sf</sub>
	V	Hz	min <sup>-1</sup>	W	A	dB(A)	m <sup>3</sup> /h	Pa
1	230	50	4890	1022	4.47	91	1655	0
2	230	50	4800	1150	5.00	89	1405	1000
3	230	50	4850	1117	4.87	81	1105	2000
4	230	50	5005	920	4.01	79	685	2900

